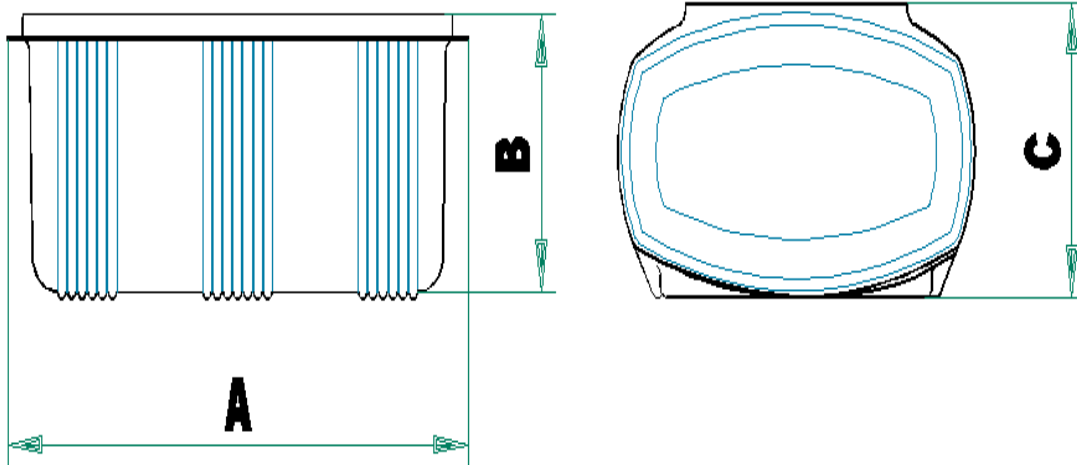

Document No:	P13-ÜT73
Issue Date	15.11.2012
Revision No	00
Revision Date	00
Page No	1/1

**OHC V62 SLOVENYA 250 CC OVAL HINGED**

Dimensions	A (mm)	B (mm)	C (mm)
	95	41	132

**WEIGHT**

MIN	MAX
<b>9,50</b>	<b>10,00</b>

PRODUCT INFORMATION						
Piece /Kg / Time	Product Weight ±%2,5 (g)	Gross Box Weight ±%2,5 (Kg)	Quantity per Box (Pcs)	Minutes for 1000 pcs	Pcs / 1000 kg	Sheet (kg) for 1000 pcs
	9,8	7,05	600	3,13	76923,08	13

Production Details	Box per Hour (pcs)	Product per Hour (pcs)	Ullage Factor	Tool Cavity (pcs)	Production Rate (cycle / minute)	Sheet Dimensions
	32,00	19200	3,25	8	40	0,28 x 690

Knife, Box and Sleeve Bag	Knife Ref	Length of Knife (m)	Box Ref	Inner Box Dimensions L x W x H (mm)	Sleeve Bag Dimensions (mm)
	L11011927	5,9	101	580 x 397 x 430	40 x 80

**PREPARED BY**  
TEAM LEADER

**APPROVED BY**  
GENERAL MANAGER